

Product Components

- ① Electric Strike Body & Faceplate
- ② #12-24 Faceplate Mounting Screws
- ③ #8-32 Body Mounting Screws
- ④ #12 x 2 1/2" Wood Faceplate Mounting Screws
- ⑤ Plug In Connector
- ⑥ Deadlatch Tabs (742-75 only)
- ⑦ #6-32 x 5/16" Deadlatch Tabs Screws (742-75 only)
- ⑧ Keeper Shim (742-75 only)
- ⑨ #6-32 x 3/16" Keeper Shim Screws (742-75 only)

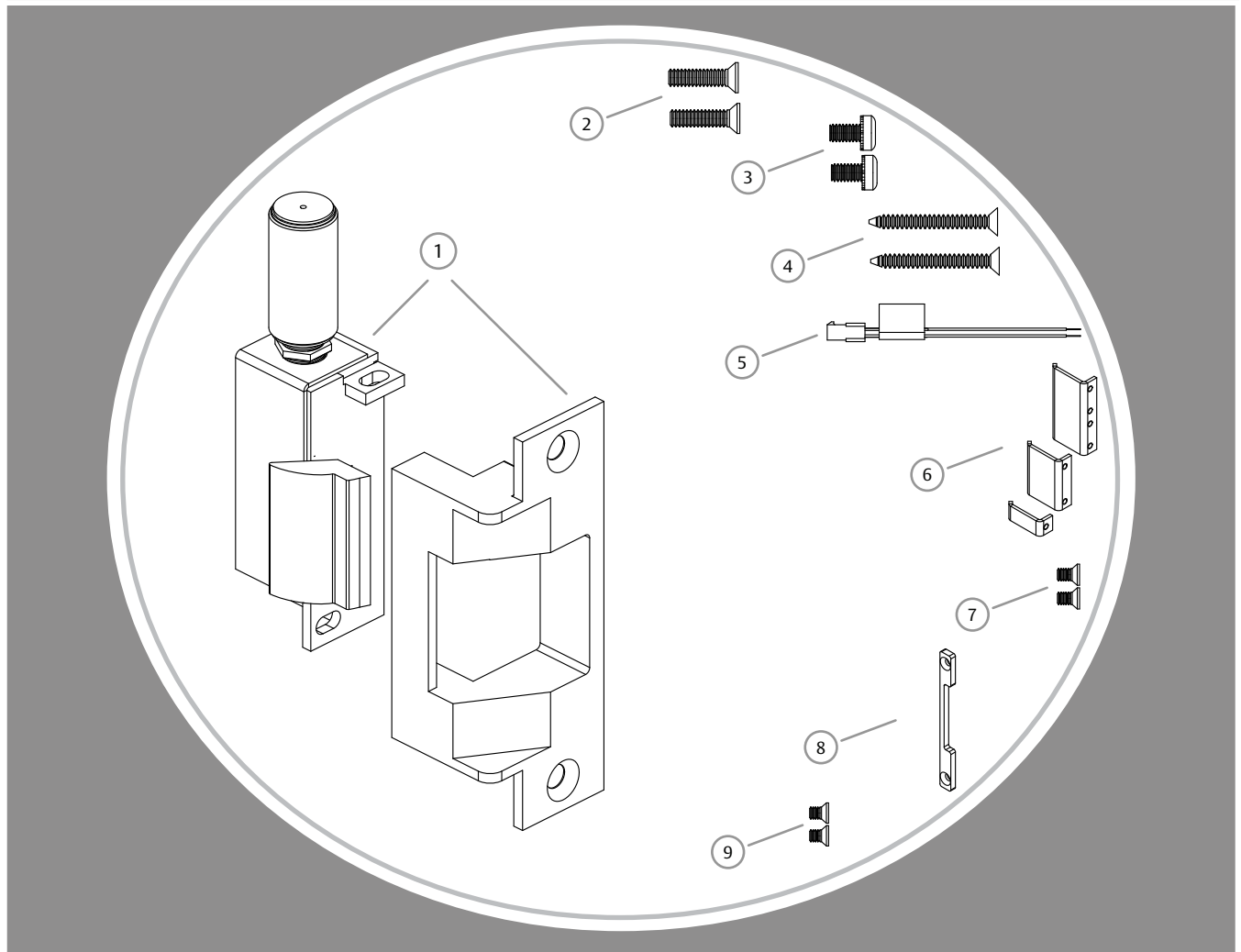

Electrical Specifications

ELECTRICAL RATINGS FOR SOLENOID		
CONTINUOUS DUTY	12VDC	24VDC
Resistance in Ohms	41	160
Amps	.29	.15
Solenoids are rated at +/- 10% indicated value.		

MINIMUM WIRE GAUGE REQUIREMENTS		
SOLENOID VOLTAGE	12VDC	24VDC
200 feet or less	18 gauge	18 gauge
200 - 300 feet	16 gauge	18 gauge
300 - 400 feet	14 gauge	16 gauge

Installation Directions

CAUTION! Before connecting any device at the installation site, verify input voltage using a multimeter. Many power supplies and low voltage transformers operate at higher levels than listed. Any input voltage exceeding 10% of the solenoid rating may cause severe damage to the unit and will void the warranty.

Prepare Strike

1. Attach the faceplate to the strike body using the #8-32 Body Mounting screws as illustrated on page 3, Diagram 2.
2. If using the LCBLCM (Latchbolt & Locking Cam Monitor), see Diagram 1 for wiring instructions.
3. The strike body ships as either a 12 or 24 volt unit and is not field selectable. Verify the available voltage is +/- 10% of the rated voltage of the strike body.

Prepare Frame

4. If using a mortise lockset, calculate offset using Diagram 3 on page 3.
5. Prepare frame using the template for your strike located on pages 4-6. If using the 742-75, see the 742-75 template on page 3 to install the Deadlatch Tab and Keeper Shim. Note: Drawing shows only one shim.

Finish Installing

6. Connect the Plug In Connector to the electric strike, and connect wires from the Plug In Connector leads to the power source.
7. Install the electric strike unit in jamb cutout, using the #12-24 x 1/2" faceplate mounting screws for metal applications, or #12 x 2-1/2: wood screws for wood applications.

Diagram 1: Monitoring Switches

Latchbolt Monitor (LBM)

White	Common
Orange	Normally Open
Green	Normally Closed



Locking Cam Monitor (LCM)

Brown	Common
Blue	Normally Open
Yellow	Normally Closed

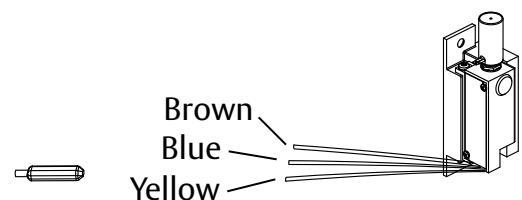
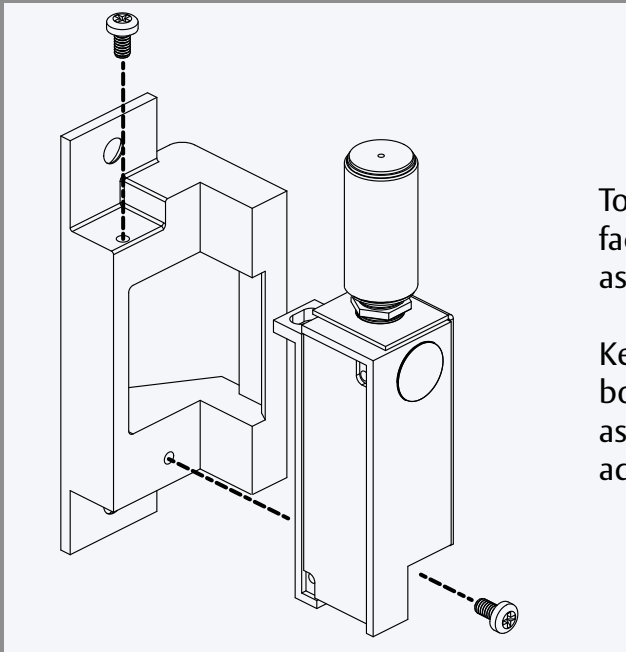

Diagram 2: Faceplate Attachment



To install the 700 series electric strike body to the faceplate, install two #8-32 Body Mounting screws as shown. Make sure bolts are tightened and secured.

Keeper position can be adjusted by loosening the #8-32 body mounting screws, and repositioning the strike body as needed. Retighten body mounting screws after adjustment is made

Diagram 3: Determining Mortise Offset

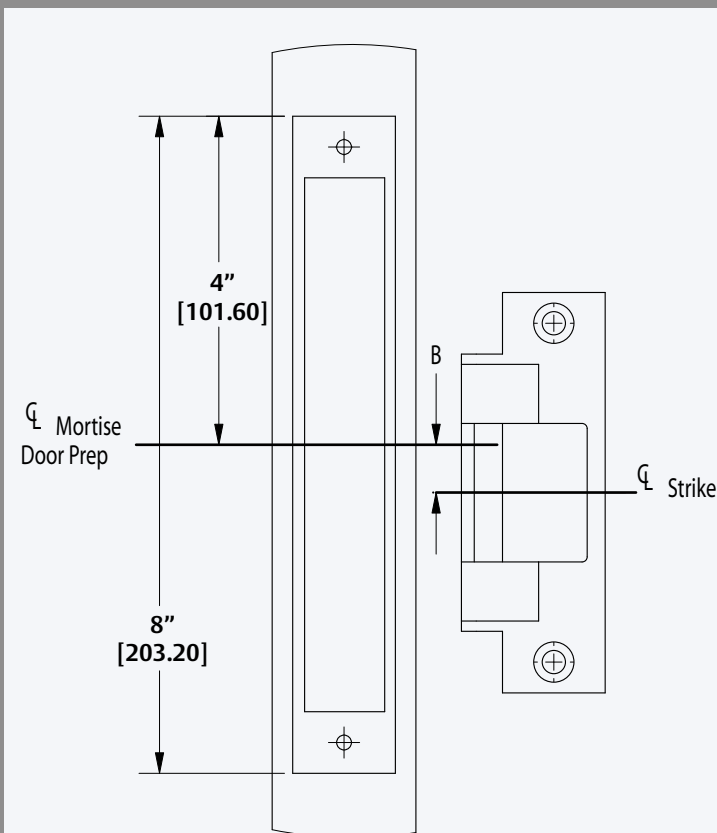

MORTISE LOCK	B
CORBIN/RUSSWIN, SARGENT (8200), YALE (8800), ARROW, FALCON	0"
BEST 34H & 37H	1/4"
SCHLAGE	3/4"
YALE (8700)	7/8"
BEST 45H & 47H*	1/8"

*Best 45H & 47H are recommended for use with the 742-75 only.

712 Template & Dimensions

(RHRB APPLICATION SHOWN)

Method of install may vary per door & frame manufacturer

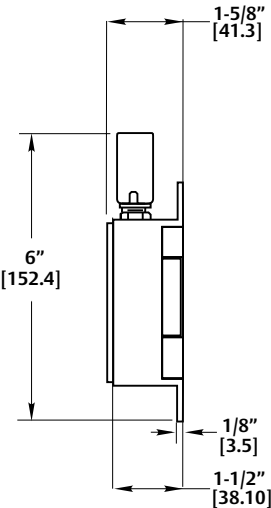
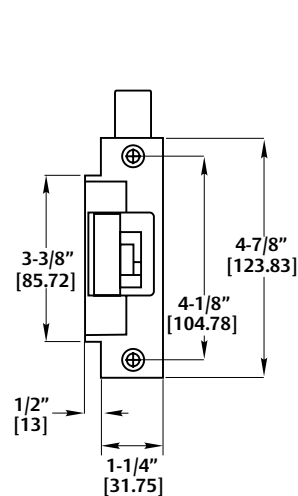
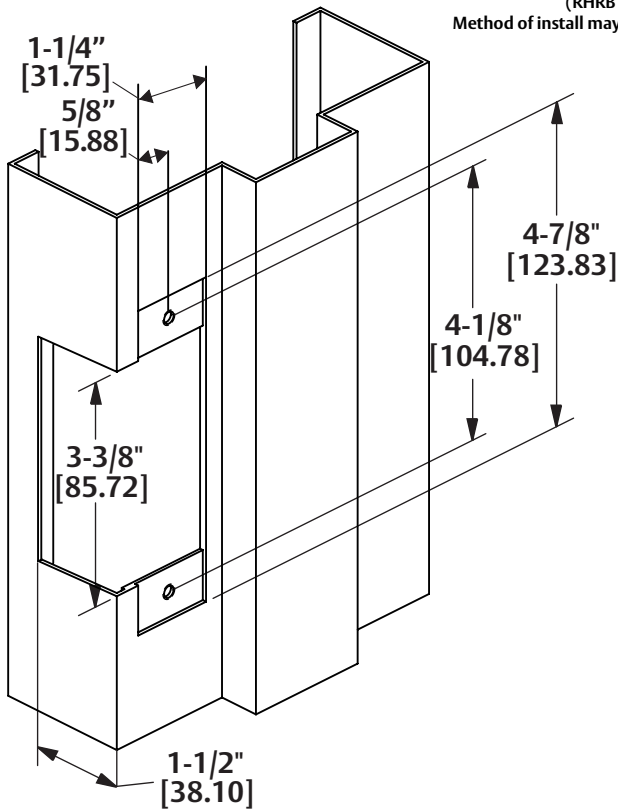

712-75 Template & Dimensions

(RHRB APPLICATION SHOWN)

Method of install may vary per door & frame manufacturer

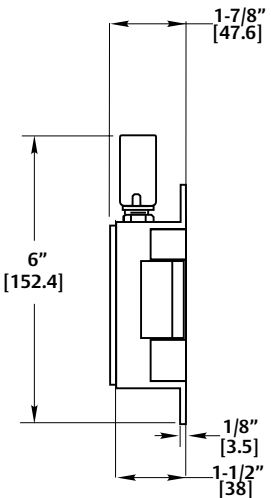
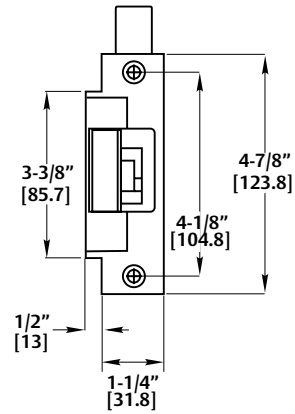
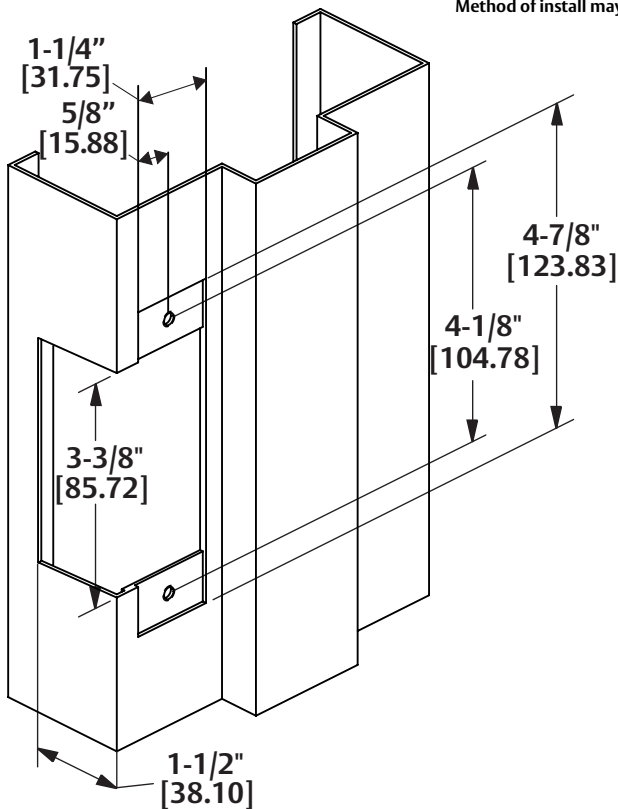

732 Template & Dimensions

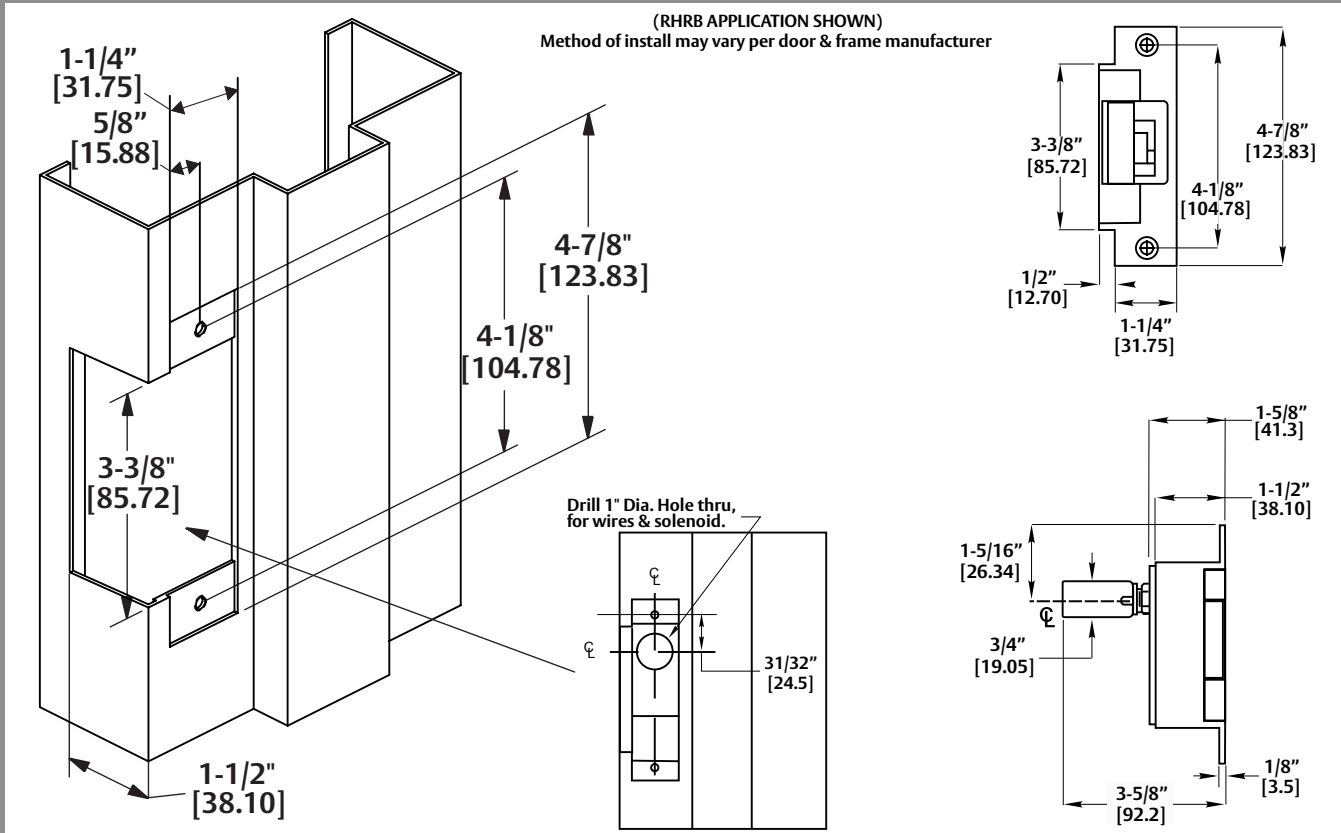

732-75 Template & Dimensions

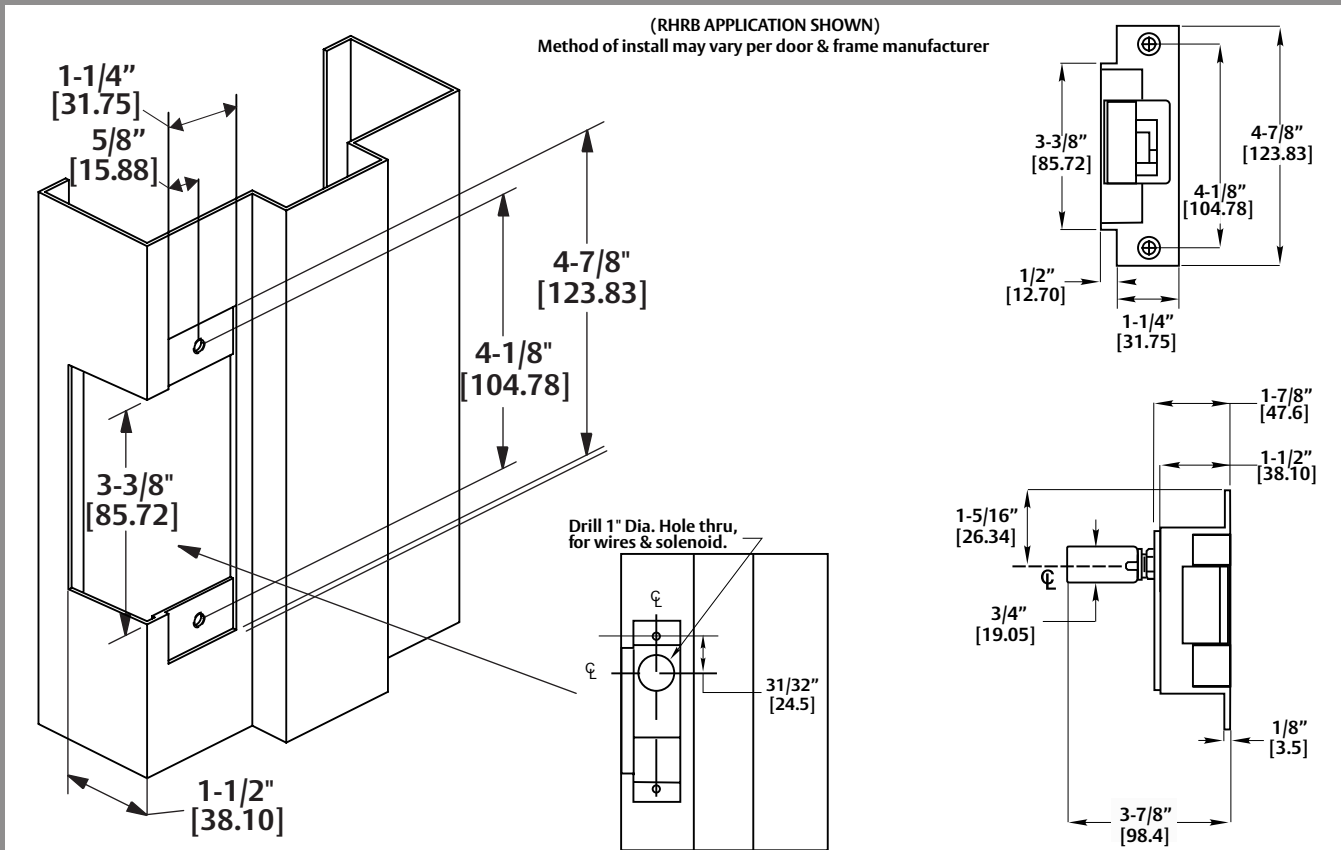

742-75 Dimensions and Template

(RHRB APPLICATION SHOWN)

Method of install may vary per door & frame manufacturer

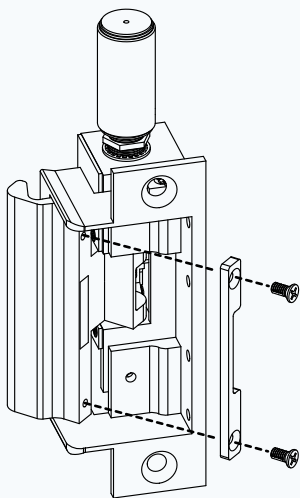
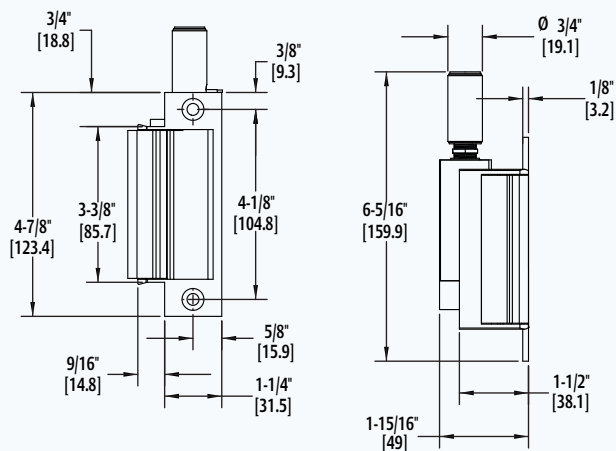
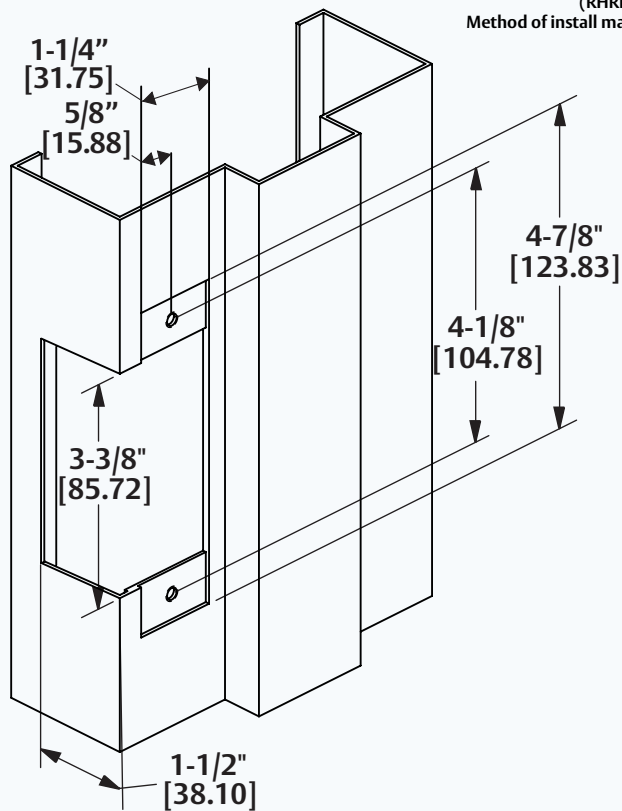

If additional horizontal adjustment is needed, install the keeper shim using the #6-32 x 3/16" keeper shims screws as illustrated.

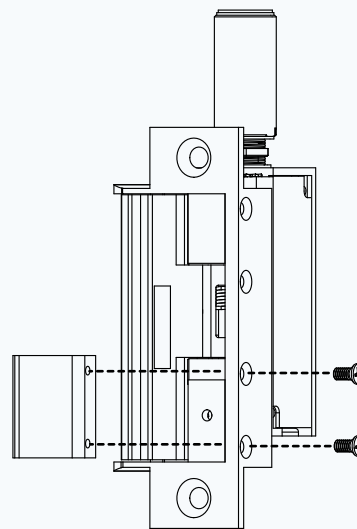

Several deadlatch tabs are included for use with the 742-75. Choose, and position the deadlatch tab so that the deadlatch is depressed when the door is closed, while staying clear of the latchbolt.

Install the deadlatch tab using the #6-32 x 5/16" deadlatch tab screws as illustrated.