



## The strongest surface mounted, multi-purpose locking solution

The 660 electro-mechanical lock is a surface-mounted electric multi-purpose lock, perfect for drawers and cabinets, operating on either 12 or 24VDC with over 1,000 lbs. of holding force.

### Standard Features

- Static strength 1,000 lbs.
- Dynamic strength over 100 ft-lbs.
- Endurance over 1,000,000 cycles
- Available in either 12 or 24 VDC
- All metal construction
- Adjustable mounting brackets with final lockdown feature
- 6 foot cable lead
- Patented design
- 3 year limited warranty

### Optional Features

- LBSM - "Locked State" Monitoring
- Pre-load version

### Accessories

- KO - 660 Key override option

### Electrical

- .24 Amps @ 12VDC continuous duty
- .12 Amps @ 24VDC continuous duty
- .70 Amps @ 12VDC (pre-load option)
- .35 Amps @ 24VDC (pre-load option)



# 660

Electro-mechanical lock

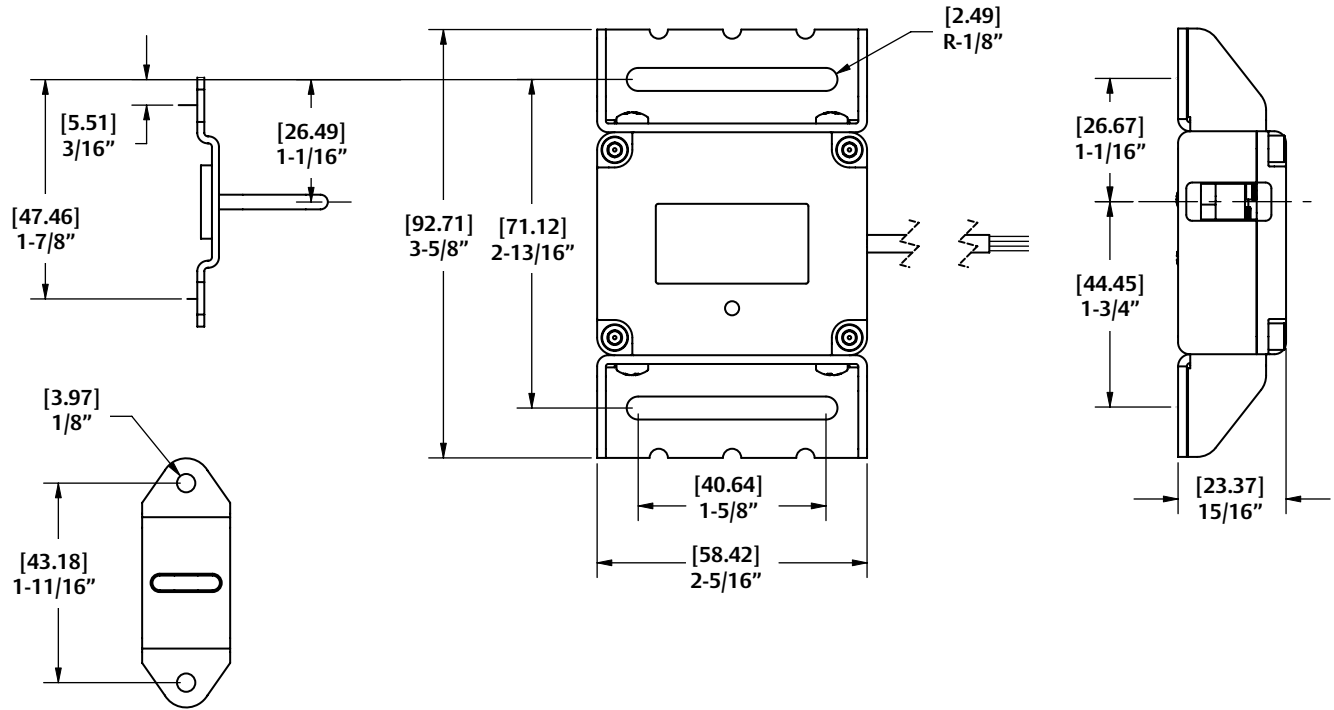

660 series

### 660 Key Override Option:

